

SMOG-HOG[®]

Electrostatic Precipitator 靜電除油煙 / 空氣淨化器

**No more placement restrictions
No more smoke or greasy emissions
A clean air solution starts here**

**對付油煙及空氣淨化的最佳辦法
清新空氣由此起**



United Air Specialists, Inc.

a CLARCOR company

COOKING EMISSIONS

煮食油煙

Eliminate Grease, Smoke, Odor ... and Worries!

Grilling and frying emissions can become a neighborhood nuisance if not probably controlled. And visible smoke and odor may alert authorities to possible compliance problems. A SMOG-HOG Electrostatic Precipitator eliminates these worries.

清除油煙氣味...和你的擔憂

如沒有好好處理廚房的油煙會對鄰近地方造成騷擾，污煙和氣味的排放也會引起相關組織的關注。SMOG-HOG靜電除油煙器可助你減輕上述問題帶來的憂慮。

A SMOG-HOG Kitchen Emission Control System in Your Restaurant

Clean air is the foundation of positive image in the community. A SMOG-HOG Kitchen Emission Control System keeps the air free of annoying smoke and greasy odors in retail developments and near high-rise buildings.

SMOG-HOG廚房排放控制系統

清新空氣有助建立一個良好社會形象。SMOG-HOG廚房排放控制系統能有效減低排出空氣的油煙量，確保空氣清新。

Keep you in Compliance

A SMOG-HOG Kitchen Emission Control System assures compliance with even the strictest federal, state or local environmental standards. Meeting air quality needs up-front eliminates unexpected retrofit costs later.

讓你符合標準

SMOG-HOG廚房排放系統符合美國聯邦政府及各地區的環保標準，可減少以後用作保持空氣質素的支出。

Save you Money

The built up grime that results from kitchen emissions can be costly in routine maintenance as well as roof replacement and repairs.

減省開支

廚房排放物引起的污垢需要定時清理，同時也需要翻新及維修。

A Wide Range of configurations

Regardless what size kitchen hood configuration is used, SMOG-HOG offers a solution, SMOG-HOG Kitchen Emission Control Systems are available for any air volume or building design parameters.

多種類選擇

SMOG-HOG廚房排放系統提供不同的風量及設計，讓客人可根據自己需要選擇。



SMOG-HOG Electrostatic Precipitator installed at Miu Fat Buddhist Monastery
妙法寺內的靜電除油煙器

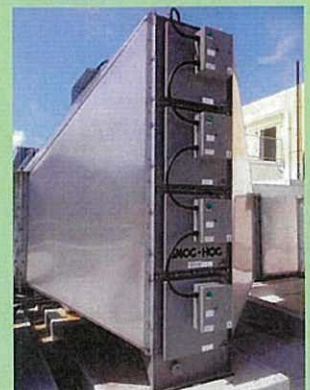

SMOG-HOG Electrostatic Precipitator installed at Kee Wah Factory
奇華工廠內的靜電除油煙器



SMOG-HOG Electrostatic Precipitator installed at Shek Wu Hui Market
石湖墟街市內的靜電除油煙器



SMOG-HOG Electrostatic Precipitator installed at Cafe de Coral
大家樂內的靜電除油煙器

WORKING PRINCIPLE

運作原理

Electrostatic Precipitator (EP) Technology

Electrostatic precipitation (EP) is the key to SMOG-HOG's superior performance. It's a sophisticated electronic solution that leaves no grease or smoke particle untouched. Unlike bag filters, which provide mechanical solutions that remove only the largest particles. ESP electrically charges even microscopic contaminants, then captures them, magnetically, in an aluminum collection cell. Only clean air is released from the system.

靜電沉澱法是SMOG-HOG的操作原理，是一個用電去解決油煙及微粒的最佳辦法，不同於紙過濾器，靜電沉澱法把所有污染物，甚至微粒子充電，然後以電磁法捕捉，並收集於收集器內。因此，只有乾淨空氣排出系統。

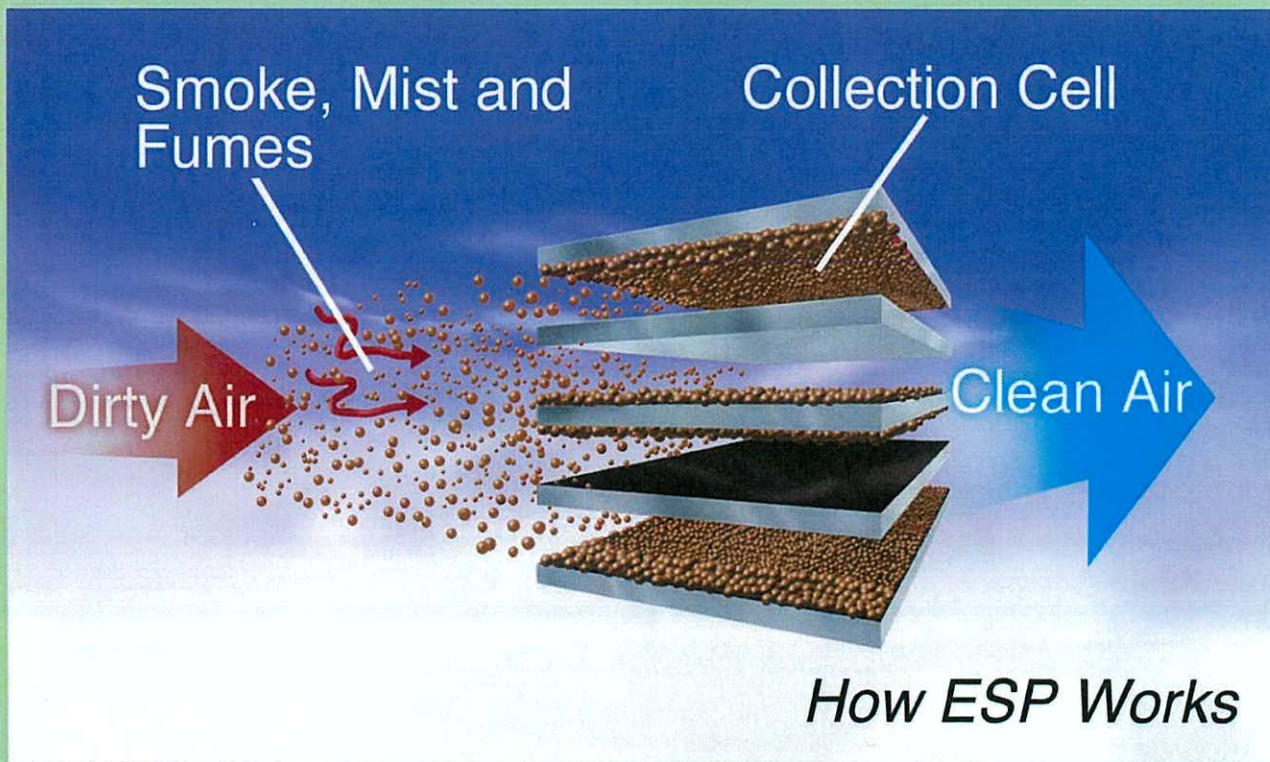

SMOG-HOG[®]

WORKING PRINCIPLE

運作原理

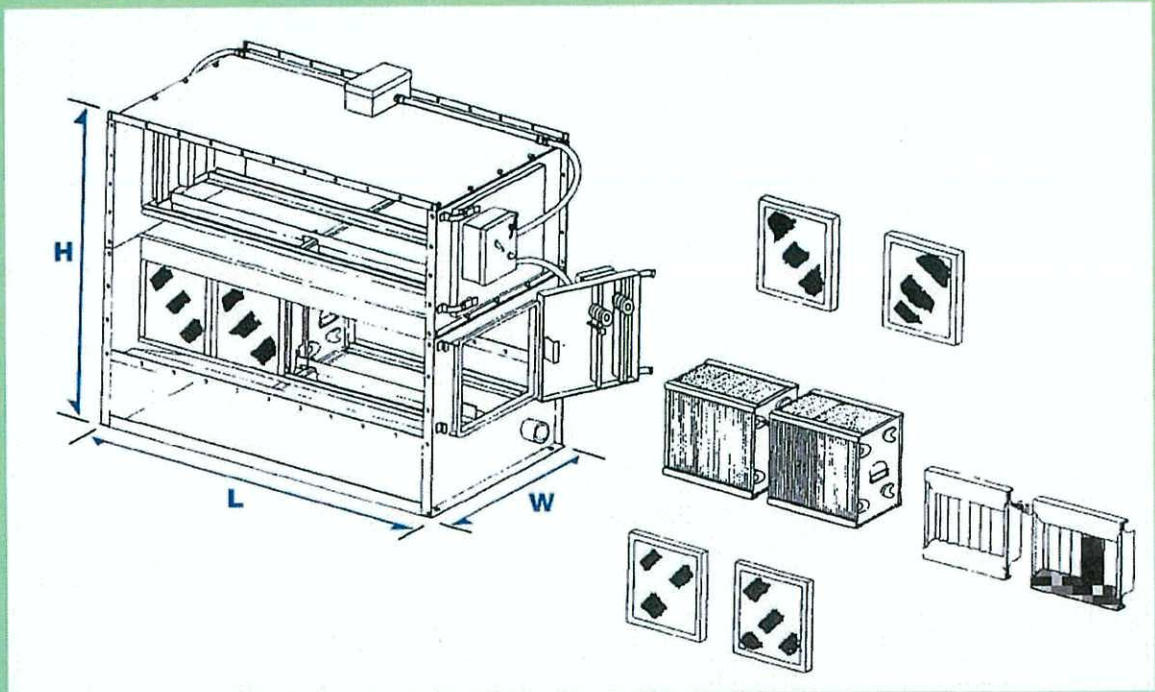

“SMOG-HOG” 靜電過濾器是一種兩階段類型靜化系統，
用作移除各種微粒及空氣污染物

“SMOG-HOG” is a two stage, Penney-type electrostatic precipitator used for
removal of submicron hydrocarbon emission and other airborne contaminants

外殼由16口徑鍍鋅鋼板製造，
外表有結實耐用的環氧樹脂漆
Cabinet made by 16 gauge galvanized steel
with a heavy-duty epoxy enamel coated exterior

25mm鋁製後置過濾器
25mm deep washable type
aluminum meash after-filter

每個收集器由一系列平衡板組成，
4.5KV - 7KV直流電壓到每個收集器
Collecting Cell contains a series of parallel plates,
alternately charged and grounded,
DC voltage range 4.5KV to 7KV supplies to each collection cell

每個電離器支持九條直徑10mil的鎢鋼線，
9.5KV - 11.5KV直流電壓到每個電離器

Ionizer supports nine 10mil diameter tungsten steel wires,
DC voltage range 9.5KV to 11.5KV supplies to each ionizer

25mm鋁製前置過濾器
25mm deep washable type
aluminum meash pre-filter

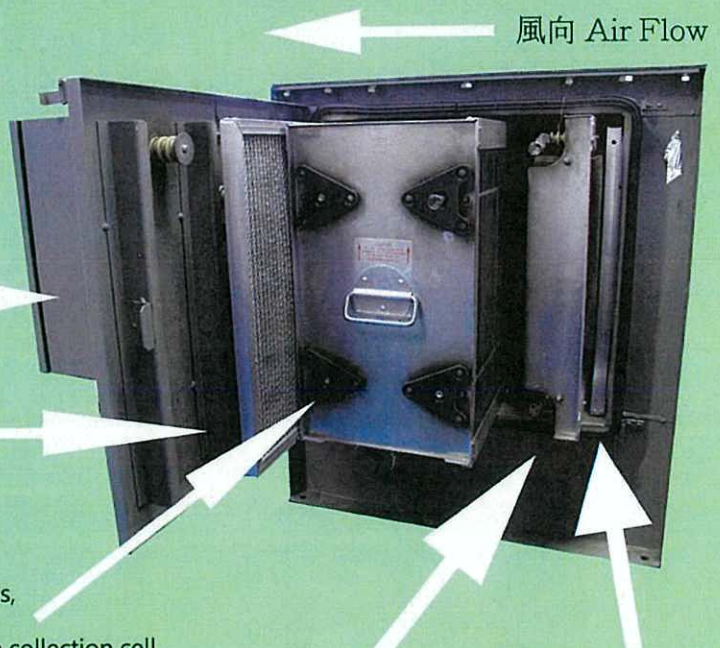

SMOG-HOG®

SMOG-HOG AIRFLOW SELECTION

不同的風量選擇

SMOG-HOG[®]

Model	COLD DOP TEST EFFICIENCY/ DUST SPOT TEST EFFICIENCY		95% Oil Removal Efficiency 95%油煙淨化率(中國國家測試)		Dimension		
	CFM	m ³ /s ≥90%	CFM	m ³ /s 95%	Size (mm)		
					L	W	H
PSH-11	1540	0.73	2373	1.12	710	677	840
PSH-11-1	2310	1.09	3560	1.68	975	677	840
PSH-12	3080	1.45	4746	2.24	1168	677	840
PSH-21	3080	1.45	4746	2.24	710	677	1552
PSH-12-1	3850	1.82	5933	2.80	1433	677	840
PSH-13	4620	2.18	7119	3.36	1622	677	840
PSH-21-1	4620	2.18	7119	3.36	975	677	1552
PSH-13-1	5390	2.54	8306	3.92	1887	677	840
PSH-14	6160	2.91	9492	4.48	2237	677	840
PSH-22	6160	2.91	9492	4.48	1168	677	1552
PSH-14-1	6930	3.27	10679	5.04	2502	677	840
PSH-22-1	7700	3.63	11865	5.60	1433	677	1552
PSH-23	9240	4.36	14238	6.72	1622	677	1552
PSH-32	9240	4.36	14238	6.72	1168	677	2155
PSH-23-1	10780	5.09	16611	7.84	1887	677	1552
PSH-32-1	11550	5.45	17798	8.40	1433	677	2155
PSH-24	12320	5.81	18984	8.96	2237	677	1552
PSH-42	12320	5.81	18984	8.96	1168	677	2758
PSH-24-1	13860	6.54	21357	10.08	2502	677	1552
PSH-33	13860	6.54	21357	10.08	1622	677	2155
PSH-42-1	15400	7.27	23730	11.20	1433	677	2758
PSH-52	15400	7.27	23730	11.20	1168	677	3362
PSH-33-1	16170	7.63	24917	11.76	1887	677	2155
PSH-34	18480	8.72	28476	13.44	2237	677	2155
PSH-43	18480	8.72	28476	13.44	1622	677	2758
PSH-62	18480	8.72	28476	13.44	1168	677	3966
PSH-52-1	19250	9.08	29663	14.00	1433	677	3362
PSH-34-1	20790	9.81	32036	15.12	2502	677	2155
PSH-43-1	21560	10.18	33222	15.68	1887	677	2758
PSH-53	23100	10.90	35595	16.80	1622	677	3362
PSH-62-1	23100	10.90	35595	16.80	1433	677	3966
PSH-44	24640	11.63	37968	17.92	2237	677	2758
PSH-53-1	26950	12.72	41528	19.60	1887	677	3362
PSH-44-1	27720	13.08	42714	20.16	2502	677	2758
PSH-63	27720	13.08	42714	20.16	1622	677	3966
PSH-54	30800	14.54	47460	22.40	2237	677	3362
PSH-63-1	32340	15.26	49833	23.52	1887	677	3966
PSH-54-1	34650	16.35	53393	25.20	2502	677	3362
PSH-64	36960	17.44	56952	26.88	2237	677	3966
PSH-64-1	41580	19.62	64071	30.24	2502	677	3966

Features

特徵

Restaurant Emissions

Particulates of grease, oil, carbons, most are of size below several μm

Industrial Emissions

Fumes, smokes, coal ash of submicron sizes

Indoor Air Pollutants

Atmospheric dust, smokes, odour of size from $0.01\mu\text{m}$ to $10\mu\text{m}$

Why is SMOG-HOG A Better Value?
為什麼選擇SMOG-HOG?

廚房排放物

工業排放物

室內排放物



Clean Air

High Efficiency in Collecting Sub-Micron Particles

- High Dust Spot Test Efficiency
- High Cold DOP Test Efficiency
- AFTL, ETL Tested UL-867, UI710 Approved
- Ozone Test Efficiency
- H.K.F.S.D. Approval Certificate

Low Operating Cost

- Low Pressure Drop give rise to low fan Power consumption
- Low Power Consumption
- Only periodic cleaning is necessary leading to Low Maintenance Cost

Easy Installation

- Unit is wholly factory assembled, only needed to connect the unit to the duct and electric supply

Safe

- High voltage is cut whenever access door is opened
- Power Pack current limited to five millamperes: Satisfy UL standard for non-lethal power supply

Services

- Experienced person for maintenance and repair
- Cleaning service available

能有效率地收集微粒子

- 高除塵效率
- 高多普勒效率
- UL-867, UL710認可
- 臭氧產量安全標準
- 香港消防處認可

運作費用低

- 低氣壓，因此風扇能量消耗低
- 低能量消耗
- 只需間中清理，維修費用低

安裝容易

- 所有配件均為原廠裝配，除塵器只需連接至風管及電源便可運作

安全

- 檢修門開啟時，高壓電流會被中斷
- 火牛電流限制在5mA，符合UL準則

服務

- 經濟豐富工人維修
- 提供清潔服務

SMOG-HOG[®]

AUTO-WASH SYSTEM

自動清洗系統



SMOG-HOG®

SMOG-HOG提供內置清洗系統的型號，系統有高架噴咀供選擇
SMOG-HOG has developed an in-place washing system.
The system is available in overhead header configurations

每部自動清洗系統均設有獨立控制箱
There is an individual control panel for each Auto-wash system

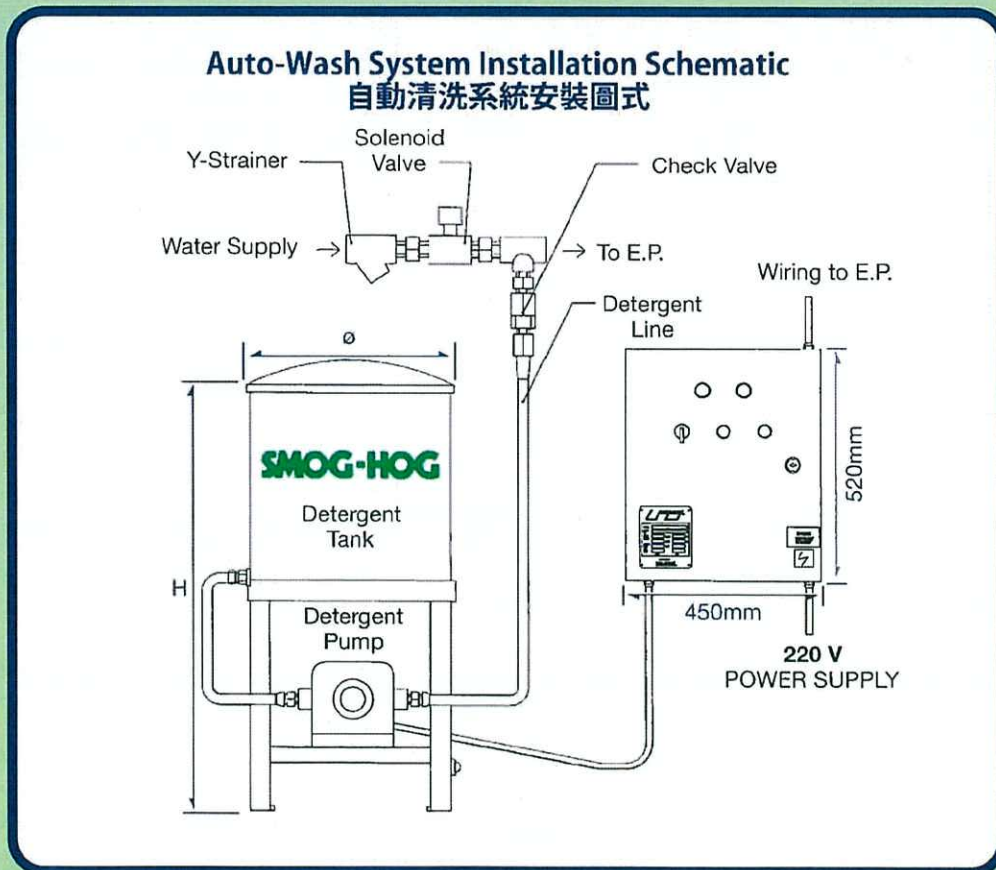

Dimension:

300mm x H 630mm for model: PSH-11/W, 11-1W, 12/W, 13/W, 14/W, 14-1W
480mm x H 1080mm for other models

AUTO-WASH SYSTEM

自動清洗系統

靜電過濾器被配以固定自動清洗系統，用作去除長時間運作而累積的污染物
自動清洗系統包括一系列裝置在各零件上的固定噴嘴
噴嘴是工廠安裝入內的，用作提供清洗動作

The electrostatic precipitator is equipped with Fixed Header Self-Cleaning System to remove built-up contaminant.

Which consists of a series of fixed nozzles mounted above the electrostatic collection components.

Nozzles are factory installed into each cabinet tier and provide washing action from above the components.

“SMOG-HOG” 型號: PSH-1X/W之自動清洗安裝

“SMOG-HOG” Auto-wash system installation for model PSH-1X/W



座地安裝
Floor Mounted



吊天安裝
Ceiling Mounted

“SMOG-HOG” 型號: PSH-2X/W之 - PSH-6X/W之自動清洗安裝

“SMOG-HOG” Auto-wash system installation for model PSH-1X/W to PSH-6X/W



座地安裝
Floor Mounted

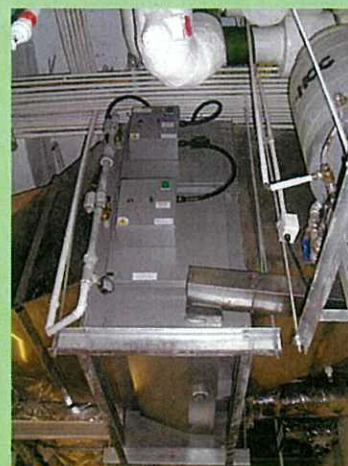

吊天安裝
Ceiling Mounted

INSTALLATION EXAMPLE 安裝範例



MAINTENANCE 維修保養

檢查服務
CHECKING SERVICE



零件維修及更換服務
SPARE PARTS REPAIR AND
REPLACEMENT SERVICE



清洗服務
CLEANING SERVICE



SMOG-HOG®

AUTO-WASH SYSTEM DEGREASER

自動清洗系統化油劑

UN766 Turbo-Zyme Heavy-Duty Presoak Degreaser

UN766特強去油劑

Suitable for "SMOG-HOG" Electrostatic Precipitators
auto-wash system

適合用於"SMOG-HOG" 靜電除油煙機自動清洗系統

Safe for use on most hard surfaces including
stainless steel, aluminum, rubber, plastic, fiberglass
and galvanized metals

適用於不鏽鋼、鋁面、橡膠、塑膠及玻璃纖維及鍍金上

No hazardous components, phosphates, butyl, alcohols and VOCs
ranked zero in all HMIS categories

不含揮發性有機化合物、磷、酒精及毒性物質，HMIS全部評級為0

Comply with US Federal non-hazardous regulation

符合美國物料安全標準

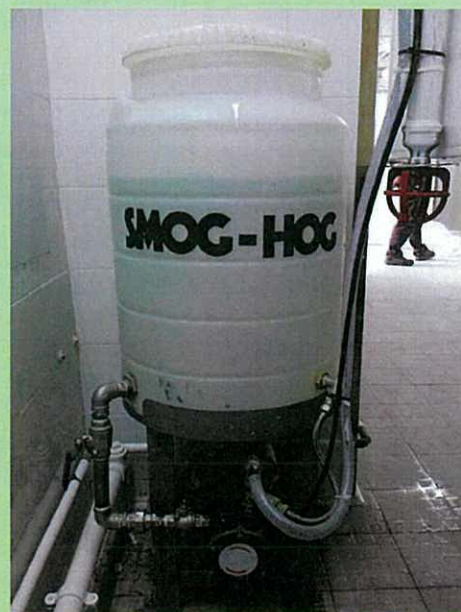

SMOG-HOG[®]

SMOG-HOG MODEL DESCRIPTION

不同型號介紹

Technical Data 技術資料

Model	Weight		Power Consumption (W)	Current (A)	Pressure Drop (Pa)	Water Side flow Rate (L/min)	Total water consumption (L)
	Without Auto-wash System (kg)	With Auto-wash System (kg)					
PSH-11	62	82	65	0.65	96	15	52.5
PSH-11-1	74	111	65	0.65	97	25	87.5
PSH-12	93	139	65	0.65	95	30	105
PSH-21	90	138	130	1.30	98	15	90
PSH-12-1	114	161	65	0.65	95	40	140
PSH-13	134	182	65	0.65	97	45	157.5
PSH-21-1	128	194	130	1.30	94	25	150
PSH-13-1	155	204	65	0.65	95	55	192.5
PSH-14	175	226	130	1.30	98	60	210
PSH-22	165	250	130	1.30	99	30	180
PSH-14-1	196	248	130	1.30	96	70	245
PSH-22-1	206	293	130	1.30	98	40	240
PSH-23	248	335	130	1.30	97	45	270
PSH-32	240	365	195	1.95	96	30	270
PSH-23-1	289	378	130	1.30	98	55	192.5
PSH-32-1	302	427	195	1.95	98	40	360
PSH-24	330	421	260	2.60	97	60	360
PSH-42	310	473	260	2.60	98	30	360
PSH-24-1	371	464	260	2.60	95	70	420
PSH-33	360	488	195	1.95	96	45	405
PSH-42-1	392	553	260	2.60	98	40	480
PSH-52	380	580	325	3.25	94	30	450
PSH-33-1	420	549	195	1.95	95	55	495
PSH-34	480	610	390	3.90	96	60	540
PSH-43	465	632	260	2.60	96	45	540
PSH-62	450	692	390	3.90	94	30	540
PSH-52-1	483	678	325	3.25	96	40	600
PSH-34-1	540	671	390	3.90	96	70	630
PSH-43-1	543	711	260	2.60	95	55	660
PSH-53	570	776	325	3.25	95	45	675
PSH-62-1	573	746	390	3.90	94	40	720
PSH-44	620	790	520	5.20	94	60	720
PSH-53-1	665	873	325	3.25	96	55	825
PSH-44-1	698	869	520	5.20	93	70	840
PSH-63	680	800	390	3.90	98	45	810
PSH-54	760	970	650	6.50	97	60	900
PSH-63-1	795	980	390	3.90	96	55	990
PSH-54-1	855	1067	650	6.50	96	70	1050
PSH-64	910	1160	780	7.80	96	60	1080
PSH-64-1	1025	1340	780	7.80	98	70	1260

OTHER PRODUCTS

其他產品

Dust-Hog

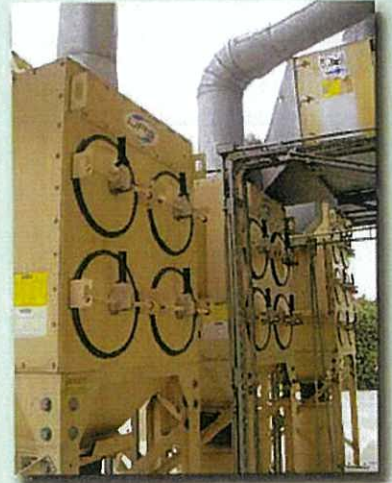

Smokeeater

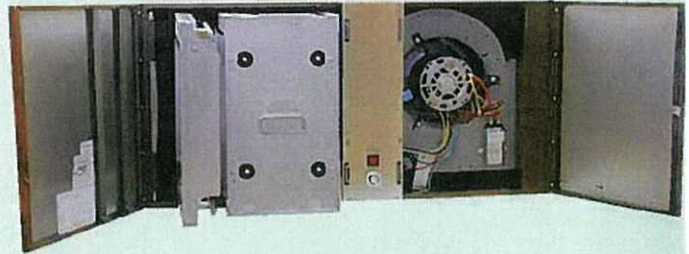

SMOG - HOG[®]



CLARCOR Filtration (China) Co., Ltd.



佳澤科技有限公司
Delta Pyramax Co., Ltd.

Hong Kong

Tel (852) 2511 2118

Fax (852) 2507 5078

上海

电话 (021) 5835 4012

(021) 5835 3432

传真 (021) 5835 3431

Website www.deltapyramax.com

Email louischeng@dpx.hk

sunnychung@dpx.hk

Clean Air, It's what we do